



HYDROSPHERE PE PUMP STATION MAXI 750L ARVEN ARVEX 150M

ARTICLE CODE: B3.09.720

ADVANTAGES:

- Ready-to-use product: easy to install
- In-house assembly
- Multi-purpose
- Multiple pump configurations possible
- Equipped with cable entry as standard
- Large bottom plate to prevent floating at high water levels

APPLICATIONS:

- Private residence
- Company
- Apartment building

TECHNICAL FEATURES:

Pump: Arven Arvex 150 M
 Flow: max. 425 l/min
 Pump head: max. 13 metres
 Power: (P2) 1.1 kW
 Mains voltage: 230 Volts 50 Hz
 Control system: Full App 1, 4-20 mA level sensor and float switch for high water alarm
 Pressure pipe: PE pipe 63 mm - PN10
 Supply pipe: PE 160 mm - PN10
 Lid: Optionally available



PUMP STATION INSTALLATION DIMENSIONS:

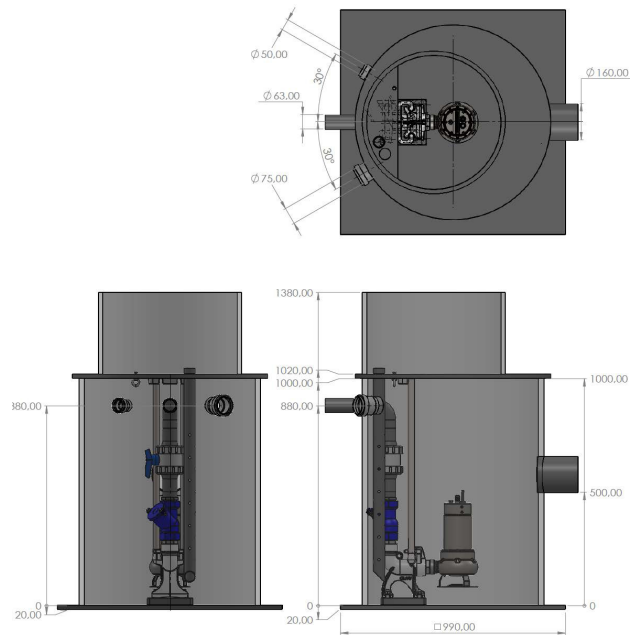

BUILT-IN COMPONENTS

Pump	Pump support	Ball check valve	Control system

OPTIONAL

Alarm	Cover A15KN	Cover D400 KN